



Toilet Pan Fixing Kit (Angled)

Installation Instructions

Parts Supplied

(two of each of the following)

- A. Hex Screw
- B. Metal Washer
- C. Angle Bracket
- D. Nylon Plug
- E. Nylon Bush
- F. Stainless Steel Screw
- G. Cap

Tools Required (not supplied)

- 1 x drill
- 1 x 10mm drill bit
- 1 x hammer
- 1 x cross head screwdriver

Assembly

1. Check and familiarise yourself with all the components.
2. Prior to carrying out the work, check the position of the W.C.
3. Once happy with the position, mark on the floor directly in line with the holes on the side on the W.C. pan.
4. Take the W.C. pan away and from the marks on the floor then draw a horizontal line approximately 50mm in where the pan would be. This is where to drill holes in the floor at a depth of 60mm.
5. Once the holes have been drilled, insert nylon plug (D).
6. Place the angle bracket (C) over the hole and use hex screw (A) and metal washer (B) to secure it to the floor. The angle bracket position can be adjusted if required, by sliding it forward or backward.
7. This should be repeated on both sides.
8. Place the pan carefully over the W.C. angle brackets into position.
9. Insert nylon bush (E) into holes in the side of the W.C. pan.
10. Take steel screw (F) and tighten through the nylon bush (E) into the angle bracket (C), be careful not to over tighten.
11. To finish place cap (G) over nylon bush (E).
12. Finally check installation and ensure pan is secure to the floor and does not move.

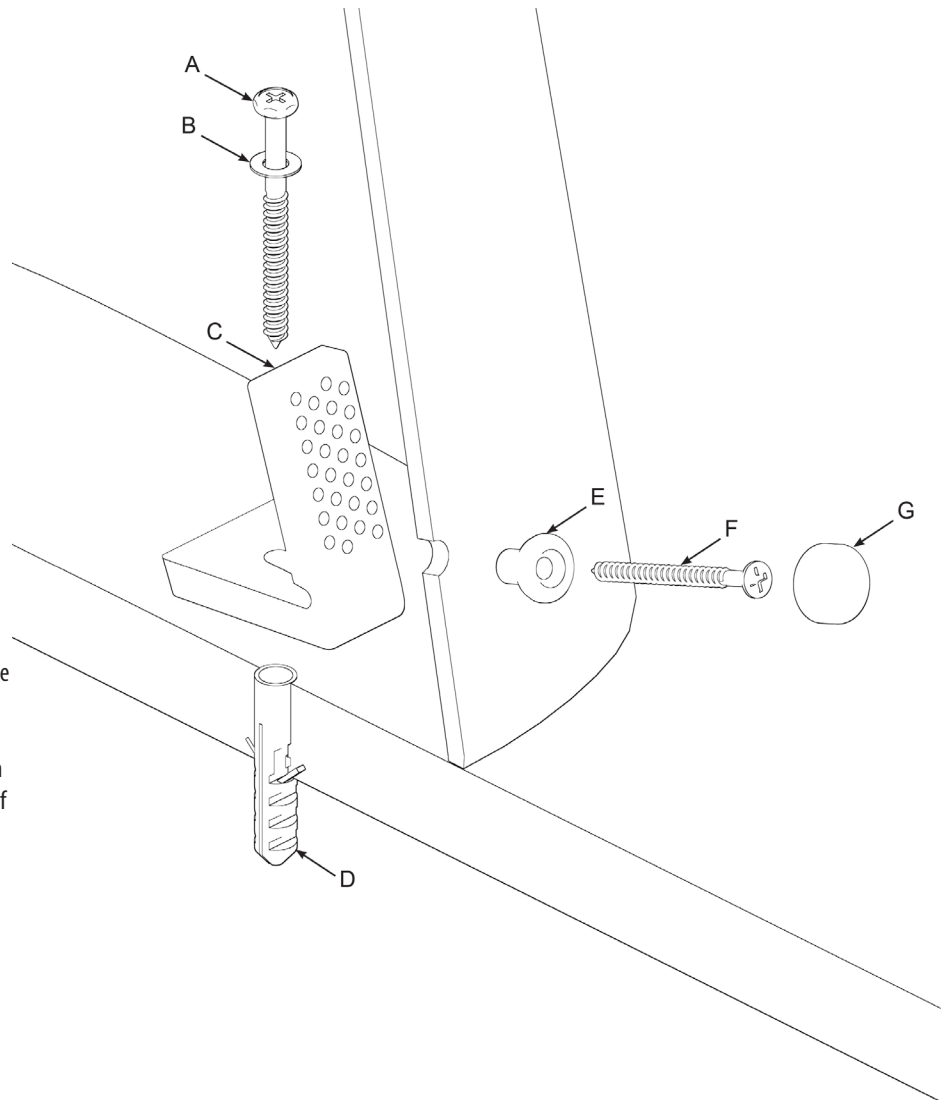

IMPORTANT INFORMATION

We accept no liability for products fitted incorrectly, and where the correct testing procedures have not been used, resulting in the escape of water. The finished surfaces on the product are hard and durable and we recommend regular cleaning to maintain their appearance. They should only be cleaned with warm soapy water, under no circumstances should any aggressive or abrasive cleaning agent be used as it can lead to deterioration of the high quality finish.



FOR MORE INFORMATION ABOUT ANY OF OUR PRODUCTS VISIT

www.vivasanitary.co.uk

UK - Units 1-3 Capitol Trading Park, Kirkby Bank Road, Knowsley Industrial Estate, Liverpool, L33 7SY
EU - Authorised Rep Compliance Ltd., GroundFloor, 71 Lower Baggot Street, Dublin, D02 P593, Ireland.

For more information please contact us:

Tel: 0151 546 0531 E-mail: sales@vivasanitary.co.uk